



**COMMONWEALTH OF PENNSYLVANIA  
DEPARTMENT OF ENVIRONMENTAL PROTECTION  
AIR QUALITY PROGRAM**

**STATE ONLY NATURAL MINOR OPERATING PERMIT**

Issue Date: August 9, 2024

Effective Date: August 9, 2024

Expiration Date: August 8, 2029

In accordance with the provisions of the Air Pollution Control Act, the Act of January 8, 1960, P.L. 2119, as amended, and 25 Pa. Code Chapter 127, the Owner, [and Operator if noted] (hereinafter referred to as permittee) identified below is authorized by the Department of Environmental Protection (Department) to operate the air emission source(s) more fully described in this permit. This Facility is subject to all terms and conditions specified in this permit. Nothing in this permit relieves the permittee from its obligations to comply with all applicable Federal, State and Local laws and regulations.

The regulatory or statutory authority for each permit condition is set forth in brackets. All terms and conditions in this permit are federally enforceable unless otherwise designated.

**State Only Permit No: 17-00006**

Natural Minor

Federal Tax Id - Plant Code: 52-1020936-1

**Owner Information**

Name: MT SAVAGE SPECIALTY REFRACTORIES CO

Mailing Address: PO BOX 60

CURWENSVILLE, PA 16833-0060

**Plant Information**

Plant: MT SAVAGE SPEC REF/CURWENSVILLE PLT

Location: 17 Clearfield County

17943 Pike Township

SIC Code: 3255 Manufacturing - Clay Refractories

**Responsible Official**

Name: MICHAEL DELUCIA

Title: PRES

Phone: (412) 367 - 9100 Ext.121

Email: MDelucia@mtsavage.com

**Permit Contact Person**

Name: ANDREW BACHER

Title: PLANT MGR

Phone: (814) 236 - 8370 Ext.422

Email: ABacher@mtsavage.com

[Signature] \_\_\_\_\_

*MUHAMMAD Q. ZAMAN, ENVIRONMENTAL PROGRAM MANAGER, NORTHCENTRAL REGION*



## SECTION A. Table of Contents

### Section A. Facility/Source Identification

Table of Contents  
Site Inventory List

### Section B. General State Only Requirements

- #001 Definitions.
- #002 Operating Permit Duration.
- #003 Permit Renewal.
- #004 Operating Permit Fees under Subchapter I.
- #005 Transfer of Operating Permits.
- #006 Inspection and Entry.
- #007 Compliance Requirements.
- #008 Need to Halt or Reduce Activity Not a Defense.
- #009 Duty to Provide Information.
- #010 Revising an Operating Permit for Cause.
- #011 Operating Permit Modifications
- #012 Severability Clause.
- #013 De Minimis Emission Increases.
- #014 Operational Flexibility.
- #015 Reactivation of Sources
- #016 Health Risk-based Emission Standards and Operating Practice Requirements.
- #017 Circumvention.
- #018 Reporting Requirements.
- #019 Sampling, Testing and Monitoring Procedures.
- #020 Recordkeeping.
- #021 Property Rights.
- #022 Alternative Operating Scenarios.
- #023 Reporting
- #024 Report Format

### Section C. Site Level State Only Requirements

- C-I: Restrictions
- C-II: Testing Requirements
- C-III: Monitoring Requirements
- C-IV: Recordkeeping Requirements
- C-V: Reporting Requirements
- C-VI: Work Practice Standards
- C-VII: Additional Requirements
- C-VIII: Compliance Certification
- C-IX: Compliance Schedule

### Section D. Source Level State Only Requirements

- D-I: Restrictions
- D-II: Testing Requirements
- D-III: Monitoring Requirements
- D-IV: Recordkeeping Requirements
- D-V: Reporting Requirements
- D-VI: Work Practice Standards
- D-VII: Additional Requirements

Note: These same sub-sections are repeated for each source!

### Section E. Source Group Restrictions

- E-I: Restrictions



## SECTION A. Table of Contents

- E-II: Testing Requirements
- E-III: Monitoring Requirements
- E-IV: Recordkeeping Requirements
- E-V: Reporting Requirements
- E-VI: Work Practice Standards
- E-VII: Additional Requirements

### Section F. Alternative Operating Scenario(s)

- F-I: Restrictions
- F-II: Testing Requirements
- F-III: Monitoring Requirements
- F-IV: Recordkeeping Requirements
- F-V: Reporting Requirements
- F-VI: Work Practice Standards
- F-VII: Additional Requirements

### Section G. Emission Restriction Summary

### Section H. Miscellaneous

**SECTION A. Site Inventory List**

Source ID	Source Name	Capacity/Throughput	Fuel/Material
031	SPACE HEATERS		
P101	PRIMARY CRUSHING & DRYING OPERATION	50.000 Tons/HR	
P102	GRINDING DEPARTMENT	50.000 Tons/HR	
P103	LINE 3 BLENDING SYSTEM	7.500 Tons/HR	
P104	LINE 1 BLENDING SYSTEM	7.500 Tons/HR	
P105	3 UD SIMPSON MIXER LINE	12.875 Tons/HR	
C001A	NORBLO FABRIC COLLECTOR #8		
C101	WET SCRUBBER		
C102A	DRACCO FABIC COLLECTOR 1		
C102B	SLY FABRIC COLLECTOR 5		
C102C	SLY FABRIC COLLECTOR 2		
C102D	SLY FABRIC COLLECTOR 4		
C102E	NORBLO FABRIC COLLECTOR 6		
C102F	AEROPULSE FABRIC COLLECTOR 18		
C103A	FULLER DRACCO FABRIC COLLECTOR 3		
C103B	FLEX-KLEEN FABRIC COLLECTOR 22		
C104	FLEX KLEEN FABRIC COLLECTOR 26		
C105	TORIT CARTRIDGE COLECTOR #25		
C105B	SLY FABRIC COLLECTOR 21		
FM01	NATURAL GAS LINE		
S001A	NORBLO COLLECTOR STACK		
S031	SPACE HEATERS STACK		
S101	WET SCRUBBER STACK		
S102A	DRACCO COLLECTOR STACK		
S102B	SLY COLLECTOR STACK		
S102C	SLY COLLECTOR STACK		
S102D	SLY COLLECTOR STACK		
S102E	NORBLO COLLECTOR STACK		
S102F	AEROPULSE COLLECTOR STACK		
S103A	FULLER COLECTOR STACK		
S103B	FLEX-KLEEN COLLECTOR STACK		
S104	FLEX-KLEEN COLLECTOR STACK		
S105	TORIT COLLECTOR STACK		
S105B	SLY COLLECTOR STACK		

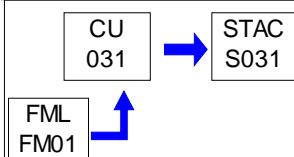
**PERMIT MAPS**



PERMIT MAPS

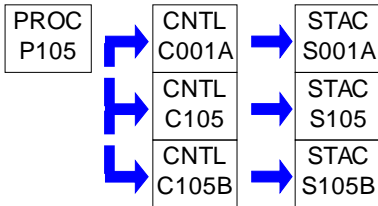
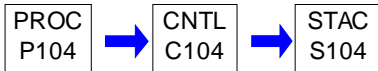
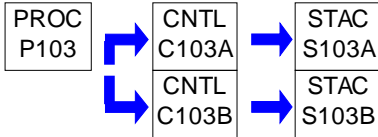
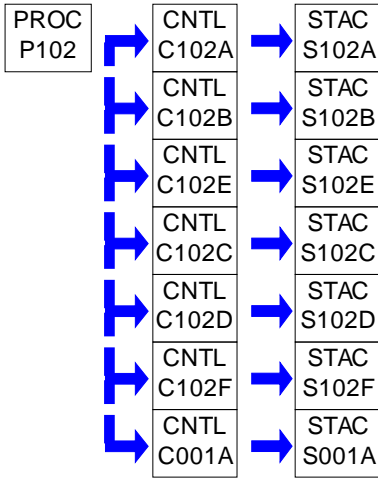

**SECTION B. General State Only Requirements****#001 [25 Pa. Code § 121.1]****Definitions.**

Words and terms that are not otherwise defined in this permit shall have the meanings set forth in Section 3 of the Air Pollution Control Act (35 P.S. § 4003) and in 25 Pa. Code § 121.1.

**#002 [25 Pa. Code § 127.446]****Operating Permit Duration.**

(a) This operating permit is issued for a fixed term of five (5) years and shall expire on the date specified on Page 1 of this permit.

(b) The terms and conditions of the expired permit shall automatically continue pending issuance of a new operating permit, provided the permittee has submitted a timely and complete application and paid applicable fees required under 25 Pa. Code Chapter 127, Subchapter I and the Department is unable, through no fault of the permittee, to issue or deny a new permit before the expiration of the previous permit.

**#003 [25 Pa. Code §§ 127.412, 127.413, 127.414, 127.446 & 127.703(b)]****Permit Renewal.**

(a) The permittee shall submit a timely and complete application for renewal of the operating permit to the appropriate Regional Air Program Manager. The application for renewal of the operating permit shall be submitted at least six (6) months and not more than 18 months before the expiration date of this permit.

(b) The application for permit renewal shall include the current permit number, a description of any permit revisions that occurred during the permit term, and any applicable requirements that were promulgated and not incorporated into the permit during the permit term. An application is complete if it contains sufficient information to begin processing the application, has the applicable sections completed and has been signed by a responsible official.

(c) The permittee shall submit with the renewal application a fee for the processing of the application as specified in 25 Pa. Code § 127.703(b). The fees shall be made payable to "The Commonwealth of Pennsylvania Clean Air Fund" and submitted with the fee form to the respective regional office.

(d) The renewal application shall also include submission of proof that the local municipality and county, in which the facility is located, have been notified in accordance with 25 Pa. Code § 127.413.

(e) The application for renewal of the operating permit shall also include submission of supplemental compliance review forms in accordance with the requirements of 25 Pa. Code § 127.412(b) and § 127.412(j).

(f) The permittee, upon becoming aware that any relevant facts were omitted or incorrect information was submitted in the permit application, shall promptly submit such supplementary facts or corrected information as necessary to address any requirements that become applicable to the source after the permittee submits a complete application, but prior to the date the Department takes action on the permit application.

**#004 [25 Pa. Code § 127.703]****Operating Permit Fees under Subchapter I.**

(a) The permittee shall pay the annual operating permit maintenance fee according to the following fee schedule in either paragraph (1) or (2) in accordance with 25 Pa. Code § 127.703(d) on or before December 31 of each year for the next calendar year.

(1) For a synthetic minor facility, a fee equal to:

(i) Four thousand dollars (\$4,000) for calendar years 2021—2025.

(ii) Five thousand dollars (\$5,000) for calendar years 2026—2030.

(iii) Six thousand three hundred dollars (\$6,300) for the calendar years beginning with 2031.

**SECTION B. General State Only Requirements**

(2) For a facility that is not a synthetic minor, a fee equal to:

- (i) Two thousand dollars (\$2,000) for calendar years 2021—2025.
- (ii) Two thousand five hundred dollars (\$2,500) for calendar years 2026—2030.
- (iii) Three thousand one hundred dollars (\$3,100) for the calendar years beginning with 2031.

(b) The applicable fees shall be made payable to "The Commonwealth of Pennsylvania Clean Air Fund" with the permit number clearly indicated and submitted to the respective regional office.

**#005 [25 Pa. Code §§ 127.450 (a)(4) and 127.464]****Transfer of Operating Permits.**

(a) This operating permit may not be transferred to another person, except in cases of transfer-of-ownership that are documented and approved by the Department.

(b) In accordance with 25 Pa. Code § 127.450(a)(4), a change in ownership of the source shall be treated as an administrative amendment if the Department determines that no other change in the permit is required and a written agreement has been submitted to the Department identifying the specific date of the transfer of permit responsibility, coverage and liability between the current and the new permittee and a compliance review form has been submitted to, and the permit transfer has been approved by, the Department.

(c) This operating permit is valid only for those specific sources and the specific source locations described in this permit.

**#006 [25 Pa. Code § 127.441 and 35 P.S. § 4008]****Inspection and Entry.**

(a) Upon presentation of credentials and other documents as may be required by law, the permittee shall allow the Department or authorized representatives of the Department to perform the following:

(1) Enter at reasonable times upon the permittee's premises where a source is located or emissions related activity is conducted, or where records are kept under the conditions of this permit;

(2) Have access to and copy, at reasonable times, any records that are kept under the conditions of this permit;

(3) Inspect at reasonable times, any facilities, equipment including monitoring and air pollution control equipment, practices, or operations regulated or required under this permit;

(4) Sample or monitor, at reasonable times, any substances or parameters, for the purpose of assuring compliance with the permit or applicable requirements as authorized by the Clean Air Act, the Air Pollution Control Act, or the regulations promulgated under the Acts.

(b) Pursuant to 35 P.S. § 4008, no person shall hinder, obstruct, prevent or interfere with the Department or its personnel in the performance of any duty authorized under the Air Pollution Control Act or regulations adopted thereunder including denying the Department access to a source at this facility. Refusal of entry or access may constitute grounds for permit revocation and assessment of criminal and/or civil penalties.

(c) Nothing in this permit condition shall limit the ability of the EPA to inspect or enter the premises of the permittee in accordance with Section 114 or other applicable provisions of the Clean Air Act.

**#007 [25 Pa. Code §§ 127.441 & 127.444]****Compliance Requirements.**

(a) The permittee shall comply with the conditions of this operating permit. Noncompliance with this permit constitutes a violation of the Clean Air Act and the Air Pollution Control Act and is grounds for one or more of the following:

**SECTION B. General State Only Requirements**

- (1) Enforcement action
- (2) Permit termination, revocation and reissuance or modification
- (3) Denial of a permit renewal application

(b) A person may not cause or permit the operation of a source which is subject to 25 Pa. Code Article III unless the source(s) and air cleaning devices identified in the application for the plan approval and operating permit and the plan approval issued for the source is operated and maintained in accordance with specifications in the applications and the conditions in the plan approval and operating permit issued by the Department. A person may not cause or permit the operation of an air contamination source subject to 25 Pa. Code Chapter 127 in a manner inconsistent with good operating practices.

(c) For purposes of Sub-condition (b) of this permit condition, the specifications in applications for plan approvals and operating permits are the physical configurations and engineering design details which the Department determines are essential for the permittee's compliance with the applicable requirements in this State-Only permit. Nothing in this sub-condition shall be construed to create an independent affirmative duty upon the permittee to obtain a predetermination from the Department for physical configuration or engineering design detail changes made by the permittee.

**#008 [25 Pa. Code § 127.441]****Need to Halt or Reduce Activity Not a Defense.**

It shall not be a defense for the permittee in an enforcement action that it was necessary to halt or reduce the permitted activity in order to maintain compliance with the conditions of this permit.

**#009 [25 Pa. Code §§ 127.442(a) & 127.461]****Duty to Provide Information.**

(a) The permittee shall submit reports to the Department containing information the Department may prescribe relative to the operation and maintenance of each source at the facility.

(b) The permittee shall furnish to the Department, in writing, information that the Department may request to determine whether cause exists for modifying, revoking and reissuing, or terminating this permit, or to determine compliance with the permit. Upon request, the permittee shall also furnish to the Department copies of records that the permittee is required to maintain in accordance with this permit.

**#010 [25 Pa. Code § 127.461]****Revising an Operating Permit for Cause.**

This operating permit may be terminated, modified, suspended or revoked and reissued if one or more of the following applies:

- (1) The permittee constructs or operates the source subject to the operating permit so that it is in violation of the Air Pollution Control Act, the Clean Air Act, the regulations thereunder, a plan approval, a permit or in a manner that causes air pollution.
- (2) The permittee fails to properly or adequately maintain or repair an air pollution control device or equipment attached to or otherwise made a part of the source.
- (3) The permittee has failed to submit a report required by the operating permit or an applicable regulation.
- (4) The EPA determines that the permit is not in compliance with the Clean Air Act or the regulations thereunder.

**#011 [25 Pa. Code §§ 127.450, 127.462, 127.465 & 127.703]****Operating Permit Modifications**

(a) The permittee is authorized to make administrative amendments, minor operating permit modifications and significant operating permit modifications, under this permit, as outlined below:



**SECTION B. General State Only Requirements**

(b) Administrative Amendments. The permittee shall submit the application for administrative operating permit amendments (as defined in 25 Pa. Code § 127.450(a)), according to procedures specified in § 127.450 unless precluded by the Clean Air Act or its regulations.

(c) Minor Operating Permit Modifications. The permittee shall submit the application for minor operating permit modifications (as defined 25 Pa. Code § 121.1) in accordance with 25 Pa. Code § 127.462.

(d) Significant Operating Permit Modifications. The permittee shall submit the application for significant operating permit modifications in accordance with 25 Pa. Code § 127.465.

(e) The applicable fees shall be made payable to "The Commonwealth of Pennsylvania Clean Air Fund" with the permit number clearly indicated and submitted to the respective regional office.

**#012 [25 Pa. Code § 127.441]****Severability Clause.**

The provisions of this permit are severable, and if any provision of this permit is determined by a court of competent jurisdiction to be invalid or unenforceable, such a determination will not affect the remaining provisions of this permit.

**#013 [25 Pa. Code § 127.449]****De Minimis Emission Increases.**

(a) This permit authorizes de minimis emission increases in accordance with 25 Pa. Code § 127.449 so long as the permittee provides the Department with seven (7) days prior written notice before commencing any de minimis emissions increase. The written notice shall:

(1) Identify and describe the pollutants that will be emitted as a result of the de minimis emissions increase.

(2) Provide emission rates expressed in tons per year and in terms necessary to establish compliance consistent with any applicable requirement.

(b) The Department may disapprove or condition de minimis emission increases at any time.

(c) Except as provided below in (d), the permittee is authorized to make de minimis emission increases (expressed in tons per year) up to the following amounts without the need for a plan approval or prior issuance of a permit modification:

(1) Four tons of carbon monoxide from a single source during the term of the permit and 20 tons of carbon monoxide at the facility during the term of the permit.

(2) One ton of NO<sub>x</sub> from a single source during the term of the permit and 5 tons of NO<sub>x</sub> at the facility during the term of the permit.

(3) One and six-tenths tons of the oxides of sulfur from a single source during the term of the permit and 8.0 tons of oxides of sulfur at the facility during the term of the permit.

(4) Six-tenths of a ton of PM<sub>10</sub> from a single source during the term of the permit and 3.0 tons of PM<sub>10</sub> at the facility during the term of the permit. This shall include emissions of a pollutant regulated under Section 112 of the Clean Air Act unless precluded by the Clean Air Act, the regulations thereunder or 25 Pa. Code Article III.

(5) One ton of VOCs from a single source during the term of the permit and 5.0 tons of VOCs at the facility during the term of the permit. This shall include emissions of a pollutant regulated under Section 112 of the Clean Air Act unless precluded by the Clean Air Act, the regulations thereunder or 25 Pa. Code Article III.

(6) Other sources and classes of sources determined to be of minor significance by the Department.

(d) In accordance with § 127.14, the permittee is authorized to install the following minor sources without the need for a plan approval or permit modification:

**SECTION B. General State Only Requirements**

- (1) Air conditioning or ventilation systems not designed to remove pollutants generated or released from other sources.
- (2) Combustion units rated at 2,500,000 or less Btu per hour of heat input.
- (3) Combustion units with a rated capacity of less than 10,000,000 Btu per hour heat input fueled by natural gas supplied by a public utility or by commercial fuel oils which are No. 2 or lighter, viscosity less than or equal to 5.82 c St, and which meet the sulfur content requirements of 25 Pa. Code §123.22 (relating to combustion units). For purposes of this permit, commercial fuel oil shall be virgin oil which has no reprocessed, recycled or waste material added.
- (4) Space heaters which heat by direct heat transfer.
- (5) Laboratory equipment used exclusively for chemical or physical analysis.
- (6) Other sources and classes of sources determined to be of minor significance by the Department.
- (e) This permit does not authorize de minimis emission increases if the emissions increase would cause one or more of the following:
- (1) Increase the emissions of a pollutant regulated under Section 112 of the Clean Air Act except as authorized in Subparagraphs (c)(4) and (5) of this permit condition.
- (2) Subject the facility to the prevention of significant deterioration requirements in 25 Pa. Code Chapter 127, Subchapter D and/or the new source review requirements in Subchapter E.
- (3) Violate any applicable requirement of this permit, the Air Pollution Control Act, the Clean Air Act, or the regulations promulgated under either of the acts.
- (f) Emissions authorized under this permit condition shall be included in the monitoring, recordkeeping and reporting requirements of this permit.
- (g) Except for de minimis emission increases, installation of minor sources made pursuant to this permit condition and Plan Approval Exemptions under 25 Pa. Code § 127.14 (relating to exemptions), the permittee is prohibited from making changes or engaging in activities that are not specifically authorized under this permit without first applying for a plan approval. In accordance with § 127.14(b), a plan approval is not required for the construction, modification, reactivation, or installation of the sources creating the de minimis emissions increase.
- (h) The permittee may not meet de minimis emission threshold levels by offsetting emission increases or decreases at the same source.

**#014 [25 Pa. Code § 127.3]****Operational Flexibility.**

The permittee is authorized to make changes within the facility in accordance with the regulatory provisions outlined in 25 Pa. Code § 127.3 (relating to operational flexibility) to implement the operational flexibility requirements provisions authorized under Section 6.1(i) of the Air Pollution Control Act and the operational flexibility terms and conditions of this permit. The provisions in 25 Pa. Code Chapter 127 which implement the operational flexibility requirements include the following:

- (1) Section 127.14 (relating to exemptions)
- (2) Section 127.447 (relating to alternative operating scenarios)
- (3) Section 127.448 (relating to emissions trading at facilities with Federally enforceable emissions caps)
- (4) Section 127.449 (relating to de minimis emission increases)
- (5) Section 127.450 (relating to administrative operating permit amendments)

**SECTION B. General State Only Requirements**

(6) Section 127.462 (relating to minor operating permit modifications)

(7) Subchapter H (relating to general plan approvals and general operating permits)

**#015 [25 Pa. Code § 127.11a]****Reactivation of Sources**

(a) The permittee may not reactivate a source that has been out of operation or production for at least one year unless the reactivation is conducted in accordance with a plan approval granted by the Department or in accordance with reactivation and maintenance plans developed and approved by the Department in accordance with 25 Pa. Code § 127.11a(a).

(b) A source which has been out of operation or production for more than five (5) years but less than 10 years may be reactivated and will not be considered a new source if the permittee satisfies the conditions specified in 25 Pa. Code § 127.11a(b).

**#016 [25 Pa. Code § 127.36]****Health Risk-based Emission Standards and Operating Practice Requirements.**

(a) When needed to protect public health, welfare and the environment from emissions of hazardous air pollutants from new and existing sources, the permittee shall comply with the health risk-based emission standards or operating practice requirements imposed by the Department, except as precluded by §§ 6.6(d)(2) and (3) of the Air Pollution Control Act [35 P.S. § 4006.6(d)(2) and (3)].

(b) A person challenging a performance or emission standard established by the Department has the burden to demonstrate that performance or emission standard does not meet the requirements of Section 112 of the Clean Air Act.

**#017 [25 Pa. Code § 121.9]****Circumvention.**

No person may permit the use of a device, stack height which exceeds good engineering practice stack height, dispersion technique or other technique which, without resulting in reduction of the total amount of air contaminants emitted, conceals or dilutes an emission of air contaminants which would otherwise be in violation of 25 Pa. Code Article III, except that with prior approval of the Department, the device or technique may be used for control of malodors.

**#018 [25 Pa. Code §§ 127.402(d) & 127.442]****Reporting Requirements.**

(a) The permittee shall comply with the applicable reporting requirements of the Clean Air Act, the regulations thereunder, the Air Pollution Control Act and 25 Pa. Code Article III including Chapters 127, 135 and 139.

(b) The permittee shall submit reports to the Department containing information the Department may prescribe relative to the operation and maintenance of any air contamination source.

(c) Reports, test data, monitoring data, notifications and requests for renewal of the permit shall be submitted to the:

Regional Air Program Manager  
PA Department of Environmental Protection  
(At the address given in the permit transmittal letter, or otherwise notified)

(d) Any records or information including applications, forms, or reports submitted pursuant to this permit condition shall contain a certification by a responsible official as to truth, accuracy and completeness. The certifications submitted under this permit shall require a responsible official of the facility to certify that based on information and belief formed after reasonable inquiry, the statements and information in the documents are true, accurate and complete.

(e) Any records, reports or information submitted to the Department shall be available to the public except for such

**SECTION B. General State Only Requirements**

records, reports or information which meet the confidentiality requirements of § 4013.2 of the Air Pollution Control Act and §§ 112(d) and 114(c) of the Clean Air Act. The permittee may not request a claim of confidentiality for any emissions data generated for the facility.

**#019 [25 Pa. Code §§ 127.441(c) & 135.5]****Sampling, Testing and Monitoring Procedures.**

(a) The permittee shall comply with the monitoring, recordkeeping or reporting requirements of 25 Pa. Code Chapter 139 and the other applicable requirements of 25 Pa. Code Article III and additional requirements related to monitoring, reporting and recordkeeping required by the Clean Air Act and the regulations thereunder including the Compliance Assurance Monitoring requirements of 40 CFR Part 64, where applicable.

(b) Unless alternative methodology is required by the Clean Air Act and regulations adopted thereunder, sampling, testing and monitoring required by or used by the permittee to demonstrate compliance with any applicable regulation or permit condition shall be conducted in accordance with the requirements of 25 Pa. Code Chapter 139.

**#020 [25 Pa. Code §§ 127.441(c) and 135.5]****Recordkeeping.**

(a) The permittee shall maintain and make available, upon request by the Department, the following records of monitored information:

- (1) The date, place (as defined in the permit) and time of sampling or measurements.
- (2) The dates the analyses were performed.
- (3) The company or entity that performed the analyses.
- (4) The analytical techniques or methods used.
- (5) The results of the analyses.
- (6) The operating conditions as existing at the time of sampling or measurement.

(b) The permittee shall retain records of any required monitoring data and supporting information for at least five (5) years from the date of the monitoring, sample, measurement, report or application. Supporting information includes the calibration data and maintenance records and original strip-chart recordings for continuous monitoring instrumentation, and copies of reports required by the permit.

(c) The permittee shall maintain and make available to the Department upon request, records including computerized records that may be necessary to comply with the reporting, recordkeeping and emission statement requirements in 25 Pa. Code Chapter 135 (relating to reporting of sources). In accordance with 25 Pa. Code Chapter 135, § 135.5, such records may include records of production, fuel usage, maintenance of production or pollution control equipment or other information determined by the Department to be necessary for identification and quantification of potential and actual air contaminant emissions.

**#021 [25 Pa. Code § 127.441(a)]****Property Rights.**

This permit does not convey any property rights of any sort, or any exclusive privileges.

**#022 [25 Pa. Code § 127.447]****Alternative Operating Scenarios.**

The permittee is authorized to make changes at the facility to implement alternative operating scenarios identified in this permit in accordance with 25 Pa. Code § 127.447.

**SECTION B. General State Only Requirements****#023 [25 Pa. Code §135.3]****Reporting**

(a) If the facility is a Synthetic Minor Facility, the permittee shall submit by March 1 of each year an annual emissions report for the preceding calendar year. The report shall include information for all active previously reported sources, new sources which were first operated during the preceding calendar year, and sources modified during the same period which were not previously reported. All air emissions from the facility should be estimated and reported.

(b) A source owner or operator of a Synthetic Minor Facility may request an extension of time from the Department for the filing of an annual emissions report, and the Department may grant the extension for reasonable cause.

**#024 [25 Pa. Code §135.4]****Report Format**

If applicable, the emissions reports shall contain sufficient information to enable the Department to complete its emission inventory. Emissions reports shall be made by the source owner or operator in a format specified by the Department.

**SECTION C. Site Level Requirements****I. RESTRICTIONS.****Emission Restriction(s).****# 001 [25 Pa. Code §123.1]****Prohibition of certain fugitive emissions**

The permittee shall not permit the emission of fugitive air contaminants from a source into the outdoor atmosphere other than the following:

- (1) Construction or demolition of buildings or structures.
- (2) Grading, paving and maintenance of roads and streets.
- (3) Use of roads and streets. Emissions from material in or on trucks, railroad cars and other vehicular equipment are not considered as emissions from use of roads and streets.
- (4) Clearing of land.
- (5) Stockpiling of materials.
- (6) Open burning operations.
- (7) Blasting in open pit mines. Emissions from drilling are not considered as emissions from blasting.
- (8) Sources and classes of sources other than those identified above, for which the permittee has obtained a determination from the Department that fugitive emissions from the source, after appropriate control, meet the following requirements:

- (a) The emissions are of minor significance with respect to causing air pollution; and
- (b) the emissions are not preventing or interfering with the attainment or maintenance of any ambient air quality standard.

**# 002 [25 Pa. Code §123.2]****Fugitive particulate matter**

The permittee shall not permit fugitive particulate matter to be emitted into the outdoor atmosphere from a source specified in condition #001 (1) through (8) above if such emissions are visible at the point the emissions pass outside the permittee's property.

**# 003 [25 Pa. Code §123.41]****Limitations**

The permittee shall not permit the emission of visible air contaminants into the outdoor atmosphere in such a manner that the opacity of the emission is either of the following:

- (1) Equal to or greater than 20% for a period or periods aggregating more than three minutes in any 1 hour.
- (2) Equal to or greater than 60% at any time.

**# 004 [25 Pa. Code §123.42]****Exceptions**

The limitations of condition #003 shall not apply when:

- (1) The presence of uncombined water is the only reason for failure of the emission to meet the limitations.
- (2) The emission results from the operation of equipment used solely to train and test persons in observing the opacity of visible emissions.
- (3) When the emission results from sources specified in condition #001(1) through (8) above.

**# 005 [25 Pa. Code §127.441]****Operating permit terms and conditions.**

[Additional authority for this permit condition is derived from 25 Pa. Code §§ 127.1 and 127.12]

There shall be no visible fugitive emissions from any portion of the refractories manufacturing facility other than what the Department determines to be of minor significance.

**II. TESTING REQUIREMENTS.****# 006 [25 Pa. Code §127.441]****Operating permit terms and conditions.**

(a) Pursuant to 25 Pa. Code § 139.3, at least 90 calendar days prior to commencing an EPA reference method testing program, a test protocol shall be submitted to the Department for review and approval. One electronic copy shall be sent to the Northcentral Regional Office (ra-epncstacktesting@pa.gov) and one electronic copy shall be sent to the PSIMS Administrator in Central Office (ra-epstacktesting@pa.gov). The test protocol shall meet all applicable requirements

**SECTION C. Site Level Requirements**

specified in the most current version of the Department's Source Testing Manual.

(b) Pursuant to 25 Pa. Code § 139.3, at least 15 calendar days prior to commencing an emission testing program, notification as to the date and time of testing shall be given to the Northcentral Regional Office. Notification shall also be sent to the Division of Source Testing and Monitoring. Notification shall not be made without prior receipt of a protocol acceptance letter from the Department.

(c) If applicable, pursuant to 40 CFR § 60.8(a), 40 CFR § 61.13(f) and 40 CFR § 63.7(g), complete test reports shall be submitted to the Department no later than 60 calendar days after completion of the on-site testing portion of an EPA reference method test program.

(d) Pursuant to 25 Pa. Code § 139.53(b) a complete test report shall include a summary of the emission results on the first page of the report indicating if each pollutant measured is within permitted limits and a statement of compliance or noncompliance with all applicable permit conditions. The summary results will include, at a minimum, the following information:

1. A statement that the owner or operator has reviewed the report from the emissions testing body and agrees with the findings.
2. Permit number(s) and condition(s) which are the basis for the evaluation.
3. Summary of results with respect to each applicable permit condition.
4. Statement of compliance or non-compliance with each applicable permit condition.

(e) Pursuant to 25 Pa. Code § 139.3, all submittals shall meet all applicable requirements specified in the most current version of the Department's Source Testing Manual.

(f) All testing shall be performed in accordance with the provisions of Chapter 139 of the Rules and Regulations of the Department of Environmental Protection.

(g) Pursuant to 25 Pa. Code §§ 139.53(a)(1) and 139.53(a)(3), electronic copies of all submittals, besides notifications, shall be sent to the Northcentral Regional Office, with deadlines verified. In addition, an electronic copy shall be sent to the PSIMS Administrator in Central Office. Email addresses are provided in the paragraph (a), above.

(h) The permittee shall insure all federal reporting requirements contained in the applicable subpart of 40 CFR are followed, including timelines more stringent than those contained herein. In the event of an inconsistency or any conflicting requirements between state and the federal, the most stringent provision, term, condition, method or rule shall be used by default.

**# 007 [25 Pa. Code §127.441]****Operating permit terms and conditions.**

If, at any time, the Department has cause to believe that air contaminant emissions from any of the sources authorized herein are in excess of the limitations specified in, or established pursuant to, any applicable regulation contained in 25 Pa. Code, Subpart C, Article III, the Department may require the permittee to conduct tests deemed necessary by the Department to determine the actual emission rate(s). The permittee shall perform such tests in accordance with applicable provisions of 25 Pa. Code, Chapter 139 (relating to sampling and testing) and in accordance with any restrictions or limitations established by the Department within one hundred and eighty (180) days of the date the Department notifies the permittee, in writing, of the testing requirement.

**# 008 [25 Pa. Code §139.1]****Sampling facilities.**

Upon the request of the Department, the permittee shall provide adequate sampling ports, safe sampling platforms and adequate utilities for the performance by the Department of tests on the source. The Department will set forth, in the request, the time period in which the facilities shall be provided, as well as the specifications for such facilities.

**# 009 [25 Pa. Code §139.11]****General requirements.**

(1) Performance tests shall be conducted while the source is operating at maximum routine operating conditions or under such other conditions, within the capacity of the equipment, as may be requested by the Department.

**SECTION C. Site Level Requirements**

(2) The Department will consider test results for approval where sufficient information is provided to verify the source conditions existing at the time of the test and where adequate data is available to show the manner in which the test was conducted. Information submitted to the Department shall include, at a minimum, all of the following:

- (a) A thorough source description, including a description of any air cleaning devices and the flue.
- (b) Process conditions, for example, the charging rate of raw material or rate of production of final product, boiler pressure, oven temperature, and other conditions which may affect emissions from the process.
- (c) The location of the sampling ports.
- (d) Effluent characteristics, including velocity, temperature, moisture content, gas density (percentage CO, CO<sub>2</sub>, O<sub>2</sub> and N<sub>2</sub>), static and barometric pressures.
- (e) Sample collection techniques employed, including procedures used, equipment descriptions and data to verify that isokinetic sampling for particulate matter collection occurred and that acceptable test conditions were met.
- (f) Laboratory procedures and results.
- (g) Calculated results.

**III. MONITORING REQUIREMENTS.****# 010 [25 Pa. Code §123.43]****Measuring techniques**

Visible emissions may be measured using either of the following:

- (1) A device approved by the Department and maintained to provide accurate opacity measurements.
- (2) Observers, trained and qualified to measure plume opacity with the naked eye or with the aid of any devices approved by the Department.

**IV. RECORDKEEPING REQUIREMENTS.****# 011 [25 Pa. Code §127.441]****Operating permit terms and conditions.**

- (1) The permittee shall conduct a weekly inspection of the facility during daylight hours while the facility is operating to detect the presence of visible air contaminant emissions, visible fugitive air contaminant emissions and malodorous air contaminant emissions in excess of applicable emission limits.
- (2) All visible air contaminant emissions, visible fugitive air contaminant emissions and malodorous air contaminant emissions observed to be in excess of an emission limit shall be reported to the manager of the facility at once.

**# 012 [25 Pa. Code §127.441]****Operating permit terms and conditions.**

- (1) The permittee shall keep a logbook of the weekly inspections required pursuant to condition #011 herein. The entries in the logbook shall include the name of the company representative performing each inspection, the date and time of each inspection, a description of any visible air contaminant emission, fugitive air contaminant emission or malodorous air contamination observed to be in excess of an emission limit, the name of the facility manager to whom notice of any observed excessive emission was given, a description of any corrective action taken to eliminate/reduce any observed excessive emission and the date and time any such corrective action was taken.
- (2) All records generated pursuant to this condition shall be retained for a minimum of five (5) years and shall be made available to the Department upon request.

**# 013 [25 Pa. Code §135.5]****Recordkeeping**

The permittee shall maintain, and make available upon request by the Department, such records, including computerized records, as may be necessary to comply with 25 Pa. Code § 135.3. These may include records of production, fuel usage, equipment maintenance or other information determined by the Department to be necessary for identification and quantification of air contaminant emissions.

**V. REPORTING REQUIREMENTS.****# 014 [25 Pa. Code §127.441]****Operating permit terms and conditions.**

The permittee shall submit all requested reports in accordance with the Department's suggested format.



**SECTION C. Site Level Requirements****# 015 [25 Pa. Code §127.442]****Reporting requirements.**

(a) The permittee shall report malfunctions, emergencies or incidents of excess emissions to the Department. A malfunction is any sudden, infrequent, and not reasonably preventable failure of air pollution control equipment, process equipment, or a process to operate in a normal or usual manner. An emergency is any situation arising from sudden and reasonably unforeseeable events beyond the control of the owner or operator of a facility which requires immediate corrective action to restore normal operation and which causes the emission source to exceed emissions, due to unavoidable increases in emissions attributable to the situation. An emergency shall not include situations caused by improperly designed equipment, lack of preventive maintenance, careless or improper operation, or operator error.

(b) When the malfunction, emergency or incident of excess emissions poses an imminent danger to the public health, safety, welfare, or environment, it shall be reported to the Department and the County Emergency Management Agency by telephone within one (1) hour after the discovery of the malfunction, emergency or incident of excess emissions. The owner or operator shall submit a written or emailed report of instances of such malfunctions, emergencies or incidents of excess emissions to the Department within three (3) business days of the telephone report.

(c) The report shall describe the following:

1. name, permit or authorization number, and location of the facility,
2. nature and cause of the malfunction, emergency or incident,
3. date and time when the malfunction, emergency or incident was first observed,
4. expected duration of excess emissions,
5. estimated rate of emissions,
6. corrective actions or preventative measures taken.

(d) Any malfunction, emergency or incident of excess emissions that is not subject to the notice requirements of paragraph (b) of this condition shall be reported to the Department by telephone within 24 hours (or by 4:00 PM of the next business day, whichever is later) of discovery and in writing or by e-mail within five (5) business days of discovery. The report shall contain the same information required by paragraph (c), and any permit specific malfunction reporting requirements.

(e) During an emergency an owner or operator may continue to operate the source at their discretion provided they submit justification for continued operation of a source during the emergency and follow all the notification and reporting requirements in accordance with paragraphs (b)-(d), as applicable, including any permit specific malfunction reporting requirements.

(f) Reports regarding malfunctions, emergencies or incidents of excess emissions shall be submitted to the appropriate DEP Regional Office Air Program Manager.

(g) Any emissions resulted from malfunction or emergency are to be reported in the annual emissions inventory report, if the annual emissions inventory report is required by permit or authorization.

**# 016 [25 Pa. Code §135.3]****Reporting**

(1) A person who owns or operates a source to which 25 Pa. Code Chapter 135 applies, and who has previously been advised by the Department to submit a source report, shall submit by March 1 of each year an annual Air Information Management Systems (AIMS) emissions report for the preceding calendar year. The report shall include information for all previously reported sources, new sources which were first operated during the proceeding calendar year and sources modified during the same period which were not previously reported.

(2) A person who receives initial notification by the Department that an annual Air Information Management Systems (AIMS) emissions report is necessary, shall submit an initial annual Air Information Management Systems (AIMS) emissions report within sixty (60) days after receiving the notification or by March 1 of the year following the year for which the report is required, whichever is later.

(3) A source owner or operator may request an extension of time from the Department for the filing of an annual Air Information Management Systems (AIMS) emissions report, and the Department may grant the extension for reasonable cause.

**SECTION C. Site Level Requirements****VI. WORK PRACTICE REQUIREMENTS.****# 017 [25 Pa. Code §123.1]****Prohibition of certain fugitive emissions**

For any source specified in condition #001(1) through (8), the permittee shall take all reasonable actions to prevent particulate matter from becoming airborne. These actions shall include, but not be limited to, the following:

- (1) Use, where possible, of water or chemicals for control of dust in the demolition of buildings or structures, construction operations, the grading of roads, or the clearing of land.
- (2) Application of asphalt, oil, water or suitable chemicals on dirt roads, material stockpiles and other surfaces which may give rise to airborne dusts.
- (3) Paving and maintenance of roadways.
- (4) Prompt removal of earth or other material from paved streets onto which earth or other material has been transported by trucking or earth moving equipment, erosion by water, or other means.

**# 018 [25 Pa. Code §127.441]****Operating permit terms and conditions.**

The permittee shall keep on hand a sufficient quantity of spare bags, cartridges, filters as required for each of the fabric collectors authorized herein in order to be able to immediately replace any requiring replacement due to deterioration.

**VII. ADDITIONAL REQUIREMENTS.****# 019 [25 Pa. Code §121.7]****Prohibition of air pollution.**

The permittee shall not permit air pollution as that term is defined in the Pennsylvania Air Pollution Control Act (35 P.S. §§ 4001 through 4015).

**# 020 [25 Pa. Code §123.31]****Limitations**

The permittee shall not permit the emission of any malodorous air contaminants into the outdoor atmosphere from any source in such a manner that the malodors are detectable outside the property of the person on whose land the source is being operated.

**# 021 [25 Pa. Code §127.441]****Operating permit terms and conditions.**

[Additional authority for this permit condition is derived from 25 Pa. Code §§ 127.1 and 127.12]

The permittee shall only process Mulcoa 47, Mulcoa 60, refractory brick bats, calcined clay or such additives as are identified in the applications and supplemental materials submitted for Plan Approvals #17-309-024 and #17-309-024A.

**# 022 [25 Pa. Code §129.14]****Open burning operations**

The permittee shall not permit the open burning of material at this facility unless in accordance with 25 Pa. Code § 129.14.

**VIII. COMPLIANCE CERTIFICATION.**

No additional compliance certifications exist except as provided in other sections of this permit including Section B (relating to State Only General Requirements).

**IX. COMPLIANCE SCHEDULE.**

No compliance milestones exist.

**SECTION D. Source Level Requirements**

Source ID: 031

Source Name: SPACE HEATERS

Source Capacity/Throughput:

**I. RESTRICTIONS.****Emission Restriction(s).**

# 001 [25 Pa. Code §123.22]

**Combustion units**

The permittee shall not permit the emission of sulfur oxides, expressed as sulfur dioxide (SO<sub>2</sub>), into the outdoor atmosphere from each heater incorporated in Source 031 in excess of the rate of 4 pounds per million Btu of heat input over any 1-hour period.

**Fuel Restriction(s).**

# 002 [25 Pa. Code §127.441]

**Operating permit terms and conditions.**

Each heater incorporated in Source 031 shall be fired only on natural gas.

**II. TESTING REQUIREMENTS.**

No additional testing requirements exist except as provided in other sections of this permit including Section B (State Only General Requirements).

**III. MONITORING REQUIREMENTS.**

No additional monitoring requirements exist except as provided in other sections of this permit including Section B (State Only General Requirements).

**IV. RECORDKEEPING REQUIREMENTS.**

No additional record keeping requirements exist except as provided in other sections of this permit including Section B (State Only General Requirements).

**V. REPORTING REQUIREMENTS.**

No additional reporting requirements exist except as provided in other sections of this permit including Section B (State Only General Requirements).

**VI. WORK PRACTICE REQUIREMENTS.**

No additional work practice requirements exist except as provided in other sections of this permit including Section B (State Only General Requirements).

**SECTION D. Source Level Requirements****VII. ADDITIONAL REQUIREMENTS.****# 003 [25 Pa. Code §127.441]****Operating permit terms and conditions.**

Source 031 consists of twenty-one (21) natural gas-fired space heaters and one (1) natural gas-fired furnace, as follows:

- Twelve (12) 0.04 million Btu per hour space heaters (3 units at Line 1 Area, 3 units at Line 3 Area, 1 unit at Material Screening Area, 1 unit at Maintenance Shop, 2 units at Specialty Simpson 3UD, and 2 units at Scrubber)
- Two (2) 0.10 million Btu per hour space heaters (1 unit at Line 3 Area and 1 unit at Maintenance Shop)
- One (1) 0.30 million Btu per hour space heater (Specialty Simpson Ramming)
- Three (3) 0.25 million Btu per hour space heaters (Break Room, Casting Area, and Specialty Simpson Ramming)
- Two (2) 0.03 million Btu per hour space heater (Lab and Restroom)
- One (1) 0.20 million Btu per hour space heater (Crushing Area)
- One (1) 0.12 million Btu per hour furnace (Office)

**SECTION D. Source Level Requirements**

Source ID: P101

Source Name: PRIMARY CRUSHING &amp; DRYING OPERATION

Source Capacity/Throughput:

50.000 Tons/HR

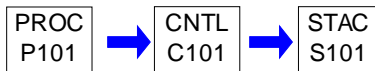
**I. RESTRICTIONS.****Emission Restriction(s).****# 001 [25 Pa. Code §123.21]****General**

The concentration of sulfur oxides, expressed as sulfur dioxide (SO<sub>2</sub>), in the effluent gas from the rotary dryer incorporated in Source P101 shall not exceed 500 parts per million, by volume, dry basis.

**# 002 [25 Pa. Code §127.441]****Operating permit terms and conditions.**

[Additional authority for this permit condition is derived from 25 Pa. Code §§ 127.1 and 127.12]

The concentration of particulate matter in the exhaust of the Source ID C101 scrubber shall not exceed 0.02 grains per dry standard cubic foot of effluent gas volume.

Compliance with this permit condition also ensures compliance with the requirements in 25 Pa. Code § 123.13.

**Fuel Restriction(s).****# 003 [25 Pa. Code §127.441]****Operating permit terms and conditions.**

[Additional authority for this permit condition is derived from 25 Pa. Code §§ 127.1 and 127.12]

The burner of the rotary dryer incorporated in Source ID P101 shall be fired only on natural gas.

**II. TESTING REQUIREMENTS.**

No additional testing requirements exist except as provided in other sections of this permit including Section B (State Only General Requirements).

**III. MONITORING REQUIREMENTS.****# 004 [25 Pa. Code §127.441]****Operating permit terms and conditions.**

[Additional authority for this permit condition is derived from 25 Pa. Code §§ 127.1 and 127.12]

The Source ID C101 scrubber authorized herein shall be equipped with instrumentation to monitor the differential pressure across the scrubber on a continuous basis.

**# 005 [25 Pa. Code §127.441]****Operating permit terms and conditions.**

[Additional authority for this permit condition is derived from 25 Pa. Code §§ 127.1 and 127.12]

The Source ID C101 scrubber authorized herein shall be equipped with flow monitoring equipment capable of measure the scrubbing solution recirculating flow rate with a minimum accuracy of +/- 1.0 gallon per minute on a continuous basis.

**# 006 [25 Pa. Code §127.441]****Operating permit terms and conditions.**

[Additional authority for this permit condition is derived from 25 Pa. Code §§ 127.1 and 127.12]

**SECTION D. Source Level Requirements**

The permittee shall observe the stack of the Source ID C101 scrubber for the presence of visible air contaminant emissions once per work shift while the rotary dryer incorporated in Source ID P101 is operating.

**# 007 [25 Pa. Code §127.441]**

**Operating permit terms and conditions.**

[Authority is also derived from 25 Pa. Code Section 127.444]

The permittee shall monitor the total hours of operation of the Source ID C101 scrubber using a runtime meter on its recirculation pump motor.

**IV. RECORDKEEPING REQUIREMENTS.**

**# 008 [25 Pa. Code §127.441]**

**Operating permit terms and conditions.**

(a) The permittee shall maintain accurate and comprehensive records of the following info pertaining to the operation of Source ID P101 authorized herein:

(1) For each calendar day when any the Source ID P101 process equipment was operated, the dates and identity of each material being unloaded which designates whether or not it was processed (dried) by the dryer incorporated in Source ID P101, the total daily amounts (tons) of each material processed, and, if applicable, the visible emissions (VE) observations on the Source ID C101 scrubber's exhaust as well as any other applicable monitoring info as required in section B herein.

(2) In addition, the Source ID C101 scrubber's differential pressure (inches of water) and recirculation/flow rate (gallons per minute) shall be recorded at least once during each calendar day when any the Source ID P101 process equipment is in operation, to verify compliance with the work practice requirements below.

(3) In addition, the dates upon which the Source ID C101 scrubber was drained, cleaned, and inspected as well as the recirculation pump hour meter readings and any other applicable monitoring info as required in section B herein as well as the dates and descriptions of the other maintenance and/or corrective actions performed on the Source ID C101 scrubber, to verify compliance with the work practices requirements below.

(b) The above records including the supporting data and other info used to derive the reported values shall be maintained for a minimum of five (5) years and made available to the Department upon request.

**V. REPORTING REQUIREMENTS.**

No additional reporting requirements exist except as provided in other sections of this permit including Section B (State Only General Requirements).

**VI. WORK PRACTICE REQUIREMENTS.**

No additional work practice requirements exist except as provided in other sections of this permit including Section B (State Only General Requirements).

**VII. ADDITIONAL REQUIREMENTS.**

**# 009 [25 Pa. Code §127.441]**

**Operating permit terms and conditions.**

[Additional authority for this permit condition is derived from 25 Pa. Code §§ 127.1 and 127.12]

The Source ID C101 scrubber authorized herein shall be equipped with a pumped recirculating scrubbing solution system. The pumped recirculating scrubbing solution system shall be operated at all times that the Source ID C101 scrubber is in operation.

**SECTION D. Source Level Requirements****# 010 [25 Pa. Code §127.441]****Operating permit terms and conditions.**

[Additional authority for this permit condition is derived from 25 Pa. Code §§ 127.1 and 127.12]

The Source ID C101 scrubber authorized herein shall operate at a minimum scrubbing solution recirculation rate of 60 gallons per minute and at a minimum differential pressure of 14.0 inches of water.

**# 011 [25 Pa. Code §127.441]****Operating permit terms and conditions.**

[Additional authority for this permit condition is derived from 25 Pa. Code §§ 127.1 and 127.12]

At any time the Source ID C101 scrubber authorized herein is being used to control the air contaminant emissions from the equipment identified in subsections (1) through (3), (6) through (8) and (10) of condition #014, the rotary dryer identified in subsection (9) of condition #014 shall not be operated.

**# 012 [25 Pa. Code §127.441]****Operating permit terms and conditions.**

[Additional authority for this permit condition is derived from 25 Pa. Code §§ 127.1 and 127.12]

The air contaminant emissions from the equipment identified in subsections (1) through (8) and (10) of condition #014 shall be controlled by the Source ID C101 scrubber at all times the respective equipment is being used to process dry material (material that does not need to be processed through the rotary dryer).

**# 013 [25 Pa. Code §127.441]****Operating permit terms and conditions.**

[Authority is also derived from 25 Pa. Code Section 127.444]

The Source ID C101 scrubber shall be drained and cleaned on a periodic basis no later than every 40 total hours of operation since the last. The scrubber shall also be inspected as part of this draining and cleaning process to determine if repair or other corrective action is needed. Should any repairs or corrective actions be necessary, such actions shall be taken immediately.

**# 014 [25 Pa. Code §127.441]****Operating permit terms and conditions.**

[Additional authority for this permit condition is derived from 25 Pa. Code §§ 127.1 and 127.12]

Source IDs P101 are the primary refractory materials crushing and drying equipment operations which consists of the following:

- (1) One (1) Rexnord model 1706-M14 apron feeder
- (2) One (1) NARCO 36" x 67'-2" belt conveyer (Conveyor #G2)
- (3) One (1) NARCO transfer chute
- (4) One (1) Telsmith model 15 x 38 jaw crusher
- (5) One (1) Eagle Iron Works model BM-D1770 roll crusher
- (6) One (1) NARCO shuttle conveyer
- (7) One (1) NARCO 24" x 95'-10" belt conveyer (Conveyor #G5)
- (8) One (1) NARCO 24" x 13'-10" belt conveyer (Conveyor #G5A)
- (9) One (1) McDermott Brothers model 8'x60' rotary dryer with an integral 3.0 million Btu per hour natural gas-fired burner
- (10) One (1) NARCO 24" x 72'-6" belt conveyer (Conveyor #G7)
- (11) One (1) 25-ton capacity bypass hopper
- (12) One (1) custom built 24" x 26'-5" bypass conveyer

The air contaminant emissions from Source P101 shall be controlled by an Entoleter model #0501/0501 Centrifield Vortex wet scrubber (Source ID C101). The permittee shall not operate the equipment identified in subsections (11) and (12) of Source P101 at the same time as the equipment identified in subsections (1) through (10) of Source P101 are being operated.

**SECTION D. Source Level Requirements**

Source ID: P102

Source Name: GRINDING DEPARTMENT

Source Capacity/Throughput:

50.000 Tons/HR

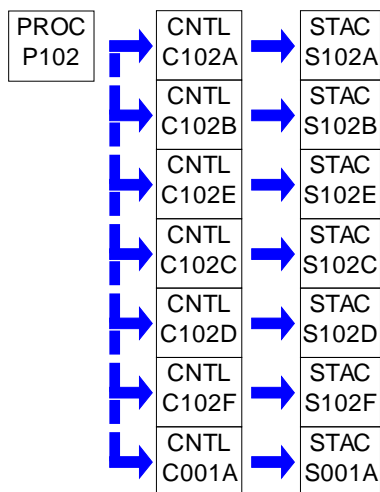
**I. RESTRICTIONS.****Emission Restriction(s).****# 001 [25 Pa. Code §127.441]****Operating permit terms and conditions.**

[Additional authority for this permit condition is derived from 25 Pa. Code §§ 127.1 and 127.12]

The concentration of particulate matter in the exhaust of Control Devices C001A and C102A through C102F shall not exceed 0.01 grains per dry standard cubic foot of effluent gas volume. Additionally, there shall be no visible emissions from the exhaust of Control Devices C001A and C102A through C102F at any time (other than steam or water vapor).

Compliance with this permit condition assures compliance with the requirements in 25 Pa. Code § 123.13.

**II. TESTING REQUIREMENTS.**

No additional testing requirements exist except as provided in other sections of this permit including Section B (State Only General Requirements).

**III. MONITORING REQUIREMENTS.****# 002 [25 Pa. Code §127.441]****Operating permit terms and conditions.**

[Additional authority for this permit condition is derived from 25 Pa. Code §§ 127.1 and 127.12]

Control Devices C001A and C102A through C102F shall be equipped with instrumentation to monitor the differential pressure across each fabric collector on a continuous basis.

**# 003 [25 Pa. Code §127.441]****Operating permit terms and conditions.**

[Additional authority for this permit condition is derived from 25 Pa. Code §§ 127.1 and 127.12]

The permittee shall inspect Control Devices C001A and C102A through C102F at least once every three (3) months for damaged or worn bags.



**SECTION D. Source Level Requirements****IV. RECORDKEEPING REQUIREMENTS.****# 004 [25 Pa. Code §127.441]****Operating permit terms and conditions.**

(a) For each inspection performed pursuant to condition #003, the permittee shall keep comprehensive and accurate records of the name of the person performing the baghouse filter inspections and dye tests, the identity of each fabric collector inspected, the results of each fabric collector inspection/dye test performed, a description of the corrective actions and other maintenance performed as result of the quarterly inspections, and a copy of the manufacturer specifications and/or other good operating practice recommendations being followed.

(b) The permittee shall keep records of the differential pressure of each of the fabric collectors authorized herein taken at least once a week while the source is in operation.

(c) All records including the monitoring data and other supporting info as required pursuant to section B herein shall be retained for a minimum of five (5) years and shall be made available to the Department upon request.

**V. REPORTING REQUIREMENTS.**

No additional reporting requirements exist except as provided in other sections of this permit including Section B (State Only General Requirements).

**VI. WORK PRACTICE REQUIREMENTS.****# 005 [25 Pa. Code §127.441]****Operating permit terms and conditions.**

As applicable, all baghouse filters of the Source IDs C102A through C102E fabric collectors shall be mechanically shaken or cleaned by reverse air flow/reverse air jet at least once for every four (4) hours of continuous operation. During those periods of time when the fabric collector bags in a collector are being shaken or cleaned by reverse air flow, the equipment identified in condition #007 herein as being controlled by that collector shall not be operated.

**# 006 [25 Pa. Code §127.441]****Operating permit terms and conditions.**

[Additional authority for this permit condition is derived from 25 Pa. Code §§ 127.1 and 127.12]

The permittee shall keep on hand a sufficient quantity of spare fabric collector bags for Control Devices C001A and C102A through C102F in order to be able to immediately replace any bag requiring replacement due to deterioration resulting from routine operation of the sources and fabric collectors.

**VII. ADDITIONAL REQUIREMENTS.****# 007 [25 Pa. Code §127.441]****Operating permit terms and conditions.**

[Additional authority for this permit condition is derived from 25 Pa. Code §§ 127.1 and 127.12]

Source P102 is the screening and conveying operations which consists of the following:

- (1) One (1) NARCO 24" x 30' belt conveyor (Conveyor #G10)
- (2) One (1) NARCO 24" x 68'-6" belt conveyor (Conveyor #G8)
- (3) One (1) NARCO 24" x 40' belt conveyor (Conveyor #G9)
- (4) One (1) elephant trunk
- (5) Thirty-two (32) tipple bins
- (6) Thirty-five (35) Syntron vibratory feeders
- (7) Two (2) NARCO 18" x 30'-6" belt conveyors (Conveyors #1, 2)
- (8) Six (6) NARCO 18" x 29' belt conveyors (Conveyors #3, 4, 5, 6, 7, 8)
- (9) One (1) NARCO 15" x 24' belt conveyor (Conveyor #G32)
- (10) One (1) NARCO 30" x 38' belt conveyor (Conveyor #G33)
- (11) One (1) NARCO 18" x 20' belt conveyor (Conveyor #G35)

**SECTION D. Source Level Requirements**

- (12) One (1) NARCO 18" x 36' belt conveyor (Conveyor #G36)
- (13) One (1) NARCO 18" x 37' belt conveyor (Conveyor #G37)
- (14) Two (2) NARCO 18" x 55' belt conveyors (Conveyors #G39, G40)
- (15) One (1) NARCO 24" x 78'-6" belt conveyor (Conveyor #G45)
- (16) One (1) NARCO 20" x 265' belt conveyor (Conveyor #G46)
- (17) One (1) NARCO 18" x 115' belt conveyor (Conveyor #G47)
- (18) One (1) NARCO 24" x 57' belt conveyor (Conveyor #G51)
- (19) One (1) NARCO 20" x 49' belt conveyor (Conveyor #G52)
- (20) One (1) NARCO 18" x 26' belt conveyor (Conveyor #G53)
- (21) One (1) NARCO 24" x 32'-6" belt conveyor (Conveyor #G54)
- (22) One (1) Tidco Barmac Duopactor 5000 crusher
- (23) One (1) chute (return to Duopactor 5000 crusher from screens)
- (24) One (1) TIDCO Engineering Ltd., Model 6900 Duopactor Barmac Crusher
- (25) One (1) NARCO bucket elevator
- (26) One (1) Essmueller Company, model #B897 bucket elevator
- (27) One (1) Link Belt, model VP 148+DE 65 screen
- (28) One (1) Starr screen
- (29) Three (3) Starr screens
- (30) Two (2) Sweco screens
- (31) Forty-four (44) Pittsburgh Construction Company specialty bins
- (32) One (1) 4'x8' Midwestern Industires model MEV 48-3 triple deck screen

The air contaminant emissions from equipment identified in subsections (11) through (15), (23), (28) through (30) and (32) of Source P102 shall be controlled by a Dracco model MB 160 fabric collector (Control Device C102A (fabric collector #1)). The permittee shall not operate equipment identified in subsections (11) through (15), (23), (28) through (30) or (32) of Source P102 without the simultaneous operation of Control Device C102A.

The air contaminant emissions from equipment identified in subsections (6) through (8), (17), (18), (19), (21), (24), (25) and (27) of Source P102 shall be controlled by a Sly model Dynaclone fabric collector (Control Device C102B (fabric collector #5)). The permittee shall not operate equipment identified in subsections (6) through (8), (17), (18), (19), (21), (24), (25) and (27) of Source P102 without the simultaneous operation of Control Device C102B.

The air contaminant emissions from equipment identified in subsections (9), (10) and (26) of Source P102 shall be controlled by a Sly model 360 #102 fabric collector (Control Device C102C (fabric collector #2)). The permittee shall not operate equipment identified in subsections (9), (10) or (26) of Source P102 without the simultaneous operation of Control Device C102C.

The air contaminant emissions from equipment identified in subsection (31) of Source P102 shall be controlled by a Sly model 360 #28 fabric collector (Control Device C102D (fabric collector #4)). The permittee shall not operate equipment identified in subsection (31) of Source P102 without the simultaneous operation of Control Device C102D.

The air contaminant emissions from equipment identified in subsections (1) through (5) and (16) of Source P102 shall be controlled by a Norblo model #280 56 fabric collector (Control Device C102E (fabric collector #6)). The permittee shall not operate equipment identified in subsections (1) through (5) or (16) of Source P102 without the simultaneous operation of Control Device C102E.

The air contaminant emissions from equipment identified in subsections (6) through (8) and (18) through (22) of Source P102 shall be controlled by an Aeropulse, model 144-10 fabric collector (Control Device C102F (fabric collector #18)). The permittee shall not operate equipment identified in subsections (6) through (8) or (18) through (22) of Source P102 without the simultaneous operation of Control Device C102F.

The air contaminant emissions from equipment identified in subsection (16) shall be controlled by a Norblo model 120 AS fabric collector (Control Device C001A (fabric collector #8)). The permittee shall not operate equipment identified in subsection (16) of Source P102 without the simultaneous operation of Control Device C001A.

**SECTION D. Source Level Requirements****# 008 [25 Pa. Code §127.441]****Operating permit terms and conditions.**

The compressor(s) providing air for the pulse cleaning type fabric collectors shall be equipped with an air dryer and oil trap.

**SECTION D. Source Level Requirements**

Source ID: P103

Source Name: LINE 3 BLENDING SYSTEM

Source Capacity/Throughput:

7.500 Tons/HR

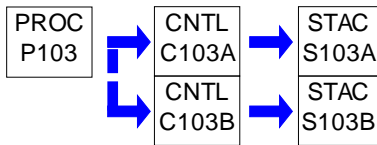
**I. RESTRICTIONS.****Emission Restriction(s).**

# 001 [25 Pa. Code §127.441]

**Operating permit terms and conditions.**

[Additional authority for this permit condition is derived from 25 Pa. Code §§ 127.1 and 127.12]

The concentration of particulate matter in the exhaust of Control Devices C103A and C103B shall not exceed 0.01 grains per dry standard cubic foot of effluent gas volume. Additionally, there shall be no visible emissions from the exhaust of Control Devices C103A and C103B at any time (other than steam or water vapor).

Compliance with this permit condition assures compliance with the requirements in 25 Pa. Code § 123.13.

**II. TESTING REQUIREMENTS.**

No additional testing requirements exist except as provided in other sections of this permit including Section B (State Only General Requirements).

**III. MONITORING REQUIREMENTS.**

# 002 [25 Pa. Code §127.441]

**Operating permit terms and conditions.**

[Additional authority for this permit condition is derived from 25 Pa. Code §§ 127.1 and 127.12]

The permittee shall inspect Control Devices C103A and C103B at least once every three (3) months for damaged or worn bags.

# 003 [25 Pa. Code §127.441]

**Operating permit terms and conditions.**

[Additional authority for this permit condition is derived from 25 Pa. Code §§ 127.1 and 127.12]

Control Devices C103A and C103B shall be equipped with instrumentation to measure the differential pressure across each collector on a continuous basis.

**IV. RECORDKEEPING REQUIREMENTS.**

# 004 [25 Pa. Code §127.441]

**Operating permit terms and conditions.**

(a) For each inspection performed pursuant to condition #002, the permittee shall keep comprehensive and accurate records of the name of the person performing the baghouse filter inspections and dye tests, the identity of each fabric collector inspected, the results of each fabric collector inspection/dye test performed, a description of the corrective actions and other maintenance performed as result of the quarterly inspections, and a copy of the manufacturer specifications and/or other good operating practice recommendations being followed.

(b) The permittee shall keep records of the differential pressure of each of the fabric collectors authorized herein taken at least once a week while the source is in operation.

**SECTION D. Source Level Requirements**

(c) All records including the monitoring data and other supporting info as required pursuant to section B herein shall be retained for a minimum of five (5) years and shall be made available to the Department upon request.

**V. REPORTING REQUIREMENTS.**

No additional reporting requirements exist except as provided in other sections of this permit including Section B (State Only General Requirements).

**VI. WORK PRACTICE REQUIREMENTS.****# 005 [25 Pa. Code §127.441]****Operating permit terms and conditions.**

All baghouse filters of the Source IDs C103A fabric collector shall be mechanically shaken at least once for every four (4) hours of continuous operation. During those periods of time when the respective fabric collector bags are being shaken, the equipment identified in condition #010 herein as being controlled by that collector shall not be operated.

**# 006 [25 Pa. Code §127.441]****Operating permit terms and conditions.**

[Additional authority for this permit condition is derived from 25 Pa. Code §§ 127.1 and 127.12]

The permittee shall keep on hand a sufficient quantity of spare fabric collector bags for Control Devices C103A and C103B in order to be able to immediately replace any bags requiring replacement due to deterioration resulting from routine operation of the sources and fabric collectors.

**VII. ADDITIONAL REQUIREMENTS.****# 007 [25 Pa. Code §127.441]****Operating permit terms and conditions.**

[Additional authority for this permit condition is derived from 25 Pa. Code §§ 127.1 and 127.12]

The bagging machine and the supersack filling station incorporated in Source P103 shall not be operated simultaneously.

**# 008 [25 Pa. Code §127.441]****Operating permit terms and conditions.**

[Additional authority for this permit condition is derived from 25 Pa. Code §§ 127.1 and 127.12]

The collection ductwork from Control Device C103B shall be equipped with devices capable of gating off (creating complete obstruction of air flow through) the ductwork to each piece of equipment identified in subsections (4), (7) and (8) of condition #010.

**# 009 [25 Pa. Code §127.441]****Operating permit terms and conditions.**

[Additional authority for this permit condition is derived from 25 Pa. Code §§ 127.1 and 127.12]

The permittee shall adhere to the following work practice standards for the collection ductwork from Control Device C103B to each piece of equipment identified in subsections (4), (7) and (8) of condition #010:

- (1) The collection ductwork associated with any source(s) not in use at any given time shall be gated off to provide optimum control of air contaminant emissions from the remaining source(s) in use at that time.
- (2) The collection ductwork associated with any source(s) in use shall not be gated off at any time.

**# 010 [25 Pa. Code §127.441]****Operating permit terms and conditions.**

[Additional authority for this permit condition is derived from 25 Pa. Code §§ 127.1 and 127.12]

**SECTION D. Source Level Requirements**

Source P103 is the Line 3 blending system which consists of the following:

- (1) One (1) hopper, Louden
- (2) One (1) skip hoist, National Engineering
- (3) One (1) #3 Simpson Mixer
- (4) One (1) weigh station, NARCO
- (5) One (1) additive mixer, Gelson - REMOVED
- (6) One (1) additive conveyor
- (7) One (1) supersack filling station
- (8) One (1) bagging machine

The air contaminant emissions from equipment identified in subsections (1) through (3) and (6) of Source P103 shall be controlled by a Fuller Dracco model #3 Unifilter fabric collector (Control Device C103A (fabric collector #3)). The permittee shall not operate equipment identified in subsections (1) through (3) and (6) of Source P103 without the simultaneous operation of Control Device C103B.

The air contaminant emissions from equipment identified in subsections (4), (7) and (8) of Source P103 shall be controlled by a Flex Kleen model 84-BVBS-25 fabric collector (Control Device C103B (fabric collector #22)). The permittee shall not operate equipment identified in subsections (4), (7) and (8) of Source P103 without the simultaneous operation of Control Device C103B.

**# 011 [25 Pa. Code §127.441]**

**Operating permit terms and conditions.**

The compressor(s) providing air for the pulse cleaning type fabric collectors shall be equipped with an air dryer and oil trap.

**SECTION D. Source Level Requirements**

Source ID: P104

Source Name: LINE 1 BLENDING SYSTEM

Source Capacity/Throughput:

7.500 Tons/HR

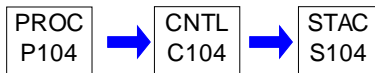
**I. RESTRICTIONS.****Emission Restriction(s).****# 001 [25 Pa. Code §127.441]****Operating permit terms and conditions.**

[Additional authority for this permit condition is derived from 25 Pa. Code §§ 127.1 and 127.12]

The concentration of particulate matter in the exhaust of Control Device C104 shall not exceed 0.01 grains per dry standard cubic foot of effluent gas volume. Additionally, there shall be no visible emissions from the exhaust of Control Device C104 at any time.

Compliance with this permit condition ensures compliance with the requirements in 25 Pa. Code § 123.13.

**II. TESTING REQUIREMENTS.**

No additional testing requirements exist except as provided in other sections of this permit including Section B (State Only General Requirements).

**III. MONITORING REQUIREMENTS.****# 002 [25 Pa. Code §127.441]****Operating permit terms and conditions.**

[Additional authority for this permit condition is derived from 25 Pa. Code §§ 127.1 and 127.12]

Control Device C104 shall be equipped with instrumentation to measure the differential pressure across the fabric collector on a continuous basis.

**# 003 [25 Pa. Code §127.441]****Operating permit terms and conditions.**

[Additional authority for this permit condition is derived from 25 Pa. Code §§ 127.1 and 127.12]

The permittee shall inspect Control Device C104 at least once every three (3) months for damaged or worn bags.

**IV. RECORDKEEPING REQUIREMENTS.****# 004 [25 Pa. Code §127.441]****Operating permit terms and conditions.**

(a) For each inspection performed pursuant to condition #003, the permittee shall keep comprehensive and accurate records of the name of the person performing the baghouse filter inspections and dye tests, the identity of each fabric collector inspected, the results of each fabric collector inspection/dye test performed, a description of the corrective actions and other maintenance performed as result of the quarterly inspections, and a copy of the manufacturer specifications and/or other good operating practice recommendations being followed.

(b) The permittee shall keep records of the differential pressure of each of the fabric collectors authorized herein taken at least once a week while the source is in operation.

(c) All records including the monitoring data and other supporting info as required pursuant to section B herein shall be retained for a minimum of five (5) years and shall be made available to the Department upon request.

**SECTION D. Source Level Requirements****V. REPORTING REQUIREMENTS.**

No additional reporting requirements exist except as provided in other sections of this permit including Section B (State Only General Requirements).

**VI. WORK PRACTICE REQUIREMENTS.****# 005 [25 Pa. Code §127.441]****Operating permit terms and conditions.**

[Additional authority for this permit condition is derived from 25 Pa. Code §§ 127.1 and 127.12]

The permittee shall keep on hand a sufficient quantity of spare fabric collector bags for Control Device C104 in order to be able to immediately replace any bag requiring replacement due to deterioration resulting from routine operation of the sources and fabric collectors.

**VII. ADDITIONAL REQUIREMENTS.****# 006 [25 Pa. Code §127.441]****Operating permit terms and conditions.**

[Additional authority for this permit condition is derived from 25 Pa. Code §§ 127.1 and 127.12]

Source P104 is the #1 Simpson mixer line which consists of the following:

- (1) One (1) batch car/weigh lorry, Louden
- (2) One (1) preblender additives hopper,
- (3) One (1) holding hopper,
- (4) one (1) weigh station, NARCO
- (5) One (1) preblend mixer, Gelson
- (6) One (1) skip hoist, National Engineering
- (7) One (1) #1 Simpson mixer
- (8) One (1) supersack filling station, NARCO

The air contaminant emissions from Source P104 shall be controlled by a Flex Kleen model 45 PVBL-36 fabric collector (Control Device C104 (fabric collector #26)). The permittee shall not operate Source P104 without the simultaneous operation of Control Device C104.

**# 007 [25 Pa. Code §127.441]****Operating permit terms and conditions.**

The compressor(s) providing air for the pulse cleaning type fabric collectors shall be equipped with an air dryer and oil trap.



**SECTION D. Source Level Requirements**

Source ID: P105

Source Name: 3 UD SIMPSON MIXER LINE

Source Capacity/Throughput:

12.875 Tons/HR

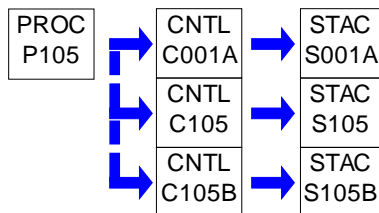
**I. RESTRICTIONS.****Emission Restriction(s).****# 001 [25 Pa. Code §127.441]****Operating permit terms and conditions.**

[Additional authority for this permit condition is derived from 25 Pa. Code §§ 127.1 and 127.12]

The concentration of particulate matter in the exhaust of Control Devices C001A, C105 and C105B shall not exceed 0.01 grains per dry standard cubic foot of effluent gas volume from each collector. Additionally, there shall be no visible emissions from Control Devices C001A, C105 and C105B at any time.

Compliance with this permit condition assures compliance with the requirements in 25 Pa. Code Section 123.13.

**II. TESTING REQUIREMENTS.**

No additional testing requirements exist except as provided in other sections of this permit including Section B (State Only General Requirements).

**III. MONITORING REQUIREMENTS.****# 002 [25 Pa. Code §127.441]****Operating permit terms and conditions.**

[Additional authority for this permit condition is derived from 25 Pa. Code §§ 127.1 and 127.12]

Control Devices C001A, C105 and C105B shall be equipped with instrumentation to measure the differential pressure across each collector on a continuous basis.

**# 003 [25 Pa. Code §127.441]****Operating permit terms and conditions.**

[Authority is also derived from 25 Pa. Code Section 127.444]

The permittee shall inspect Control Device C105 and C105 at least once every three (3) months for damaged filters or other conditions which may cause exceedances.

**IV. RECORDKEEPING REQUIREMENTS.****# 004 [25 Pa. Code §127.441]****Operating permit terms and conditions.**

(a) For each inspection performed pursuant to condition #003, the permittee shall keep comprehensive and accurate records of the name of the person performing the baghouse filter inspections and dye tests, the identity of each fabric collector inspected, the results of each fabric collector inspection/dye test performed, a description of the corrective actions and other maintenance performed as result of the quarterly inspections, and a copy of the manufacturer specifications and/or other good operating practice recommendations being followed.

**SECTION D. Source Level Requirements**

(b) The permittee shall keep records of the differential pressure of each of the fabric collectors authorized herein taken at least once a week while the source is in operation.

(c) All records including the monitoring data and other supporting info as required pursuant to section B herein shall be retained for a minimum of five (5) years and shall be made available to the Department upon request.

**V. REPORTING REQUIREMENTS.**

No additional reporting requirements exist except as provided in other sections of this permit including Section B (State Only General Requirements).

**VI. WORK PRACTICE REQUIREMENTS.****# 005 [25 Pa. Code §127.441]****Operating permit terms and conditions.**

[Additional authority for this permit condition is derived from 25 Pa. Code §§ 127.1 and 127.12]

The permittee shall keep on hand a sufficient quantity of spare fabric collector bags or cartridge collector cartridges for Control Devices C001A, C105 and C105B in order to be able to immediately replace any bags or cartridges requiring replacement due to deterioration resulting from routine operation of the sources and collectors.

**VII. ADDITIONAL REQUIREMENTS.****# 006 [25 Pa. Code §127.441]****Operating permit terms and conditions.**

[Additional authority for this permit condition is derived from 25 Pa. Code §§ 127.1 and 127.12]

Any air compressor supplying compressed air to Control Devices C001A, C105 and C105B shall be equipped with an air dryer and an oil trap.

**# 007 [25 Pa. Code §127.441]****Operating permit terms and conditions.**

[Additional authority for this permit condition is derived from 25 Pa. Code §§ 127.1 and 127.12]

The bagging machine and super sack filling station identified in subsections (a)(6) and (a)(8) of condition #008 shall not be operated simultaneously. Additionally, the air contaminant emission capture system ductwork associated with whichever of the two (bagging machine and super sack filling station) is not in operation shall be gated off from Control Device C105.

**# 008 [25 Pa. Code §127.441]****Operating permit terms and conditions.**

[Additional authority for this permit condition is derived from 25 Pa. Code Sections 127.1 and 127.12]

Source P105 consists of a 3UD mixer line and a refractory ramming material system.

(a) The 3 UD mixer line consists of the following:

- (1) Thirty-one (31) Williams & Green specialty bins
- (2) One (1) portable batch hopper
- (3) One (1) mixer, Simpson model 3 UD
- (4) One (1) NARCO specialty skip hoist
- (5) One (1) receiving hopper
- (6) One (1) bagging machine
- (7) One (1) bag dump station, Pittsburgh Construction Company
- (8) One (1) supersack filling machine

(b) The refractory ramming material system consists of the following:

- (1) One (1) Eirch model DVE-22 mixer

**SECTION D. Source Level Requirements**

- (2) One (1) belt conveyor
- (3) One (1) chute
- (4) One (1) pug mill
- (5) One (1) batch shredder

The air contaminant emissions from sources identified in subsection (a)(1) of Source P105 shall be controlled by a Norblo model 120 AS fabric collector (Control Device C001A (fabric collector #8)). The permittee shall not operate sources identified in subsections (a)(1) and (a)(2) of Source P105 without the simultaneous operation of Control Device C001A.

The air contaminant emissions from sources identified in subsections (a)(1) through (a)(8) of Source P105 shall be controlled by a Torit model 2DF12 cartridge collector (Control Device C105 (cartridge collector #25)). The permittee shall not operate sources identified in subsections (a)(1) through (a)(8) of Source P105 without the simultaneous operation of Control Device C105.

The air contaminant emissions from the bag dump station identified in subsections (a)(2) and (a)(7) of Source P105 shall be controlled by a WW Sly fabric collector (Control Device C105B (fabric collector #21)). The permittee shall not operate the bag dump station identified in subsections (a)(2) and (a)(7) of Source P105 without the simultaneous operation of Control Device C105B.

The air contaminant emissions from the mixer identified in subsection (b)(1) of Source P105 shall be controlled by a Mikro-D Pulsaire model 25-5-8-30 dust collector, which shall be exhausted inside the facility. The permittee shall not operate the mixer identified in subsection (b)(1) of Source P105 without the simultaneous operation of the Mikro-D Pulsaire dust collector.



**SECTION E. Source Group Restrictions.**



## SECTION F. Alternative Operation Requirements.

No Alternative Operations exist for this State Only facility.

**SECTION G. Emission Restriction Summary.**

No emission restrictions listed in this section of the permit.



**SECTION H. Miscellaneous.**



\*\*\*\*\* End of Report \*\*\*\*\*

---